

Cordless Riveter R1B1/R1B2

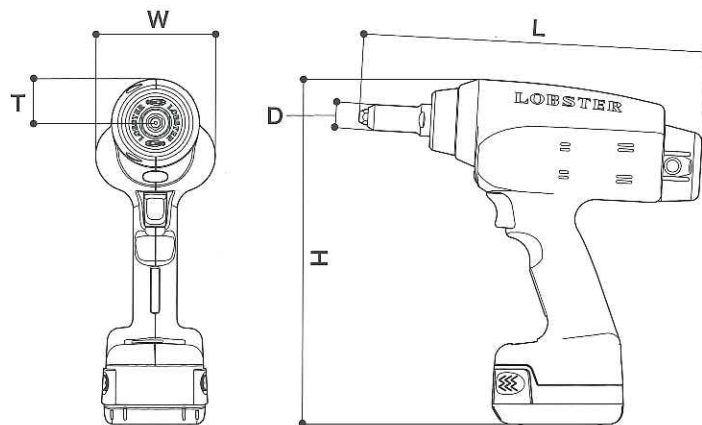

■ Riveter Specifications ※At the time battery pack BPL1415 is installed.

Model	Overall Length (L)	Height (H)	Frame Head Diam. (D)	Width (W)	Weight	(T)	Stroke	Jaw	Compatible Rivets
R1B1	260	260	21.0	90	1.9	33	22	Ultra Jaws'M'	φ2.4, 3.2, 4.0, 4.8
R1B2	268	260	23.0	90	2.0	33	22	Ultra Jaws'L'	φ4.8, 6.4 (3.2, 4.0)※

※3.2/4.0mm rivets can be used if optional parts are attached. ※6.4mm stainless steel rivets cannot be used.

■ Package Items



Model	Package Item	Code No.	
R1B1	Riveter, battery pack (BPL1415), charger (BC0075G), special case	(230V) 8848	(120V) 8840
R1B2	Riveter, battery pack(BPL1415), charger(BC0075G), special case, nosepiece(4.8, 6.4), sole use wrench	(230V) 8906	(120V) 8902
R1B1-C	※Contact the place of purchase or your nearest "LOBSTER" dealer for the price of R1B1-C and detailed specifications.	(230V) 8876	(120V) 8872



■ R1B2 accompanying items



■ Battery Pack Specifications

Model	Type	Voltage Rating	Capacity	Charging Time (※)		Code No.
				Full Charge	Charge for Practical Use	
BPL1415 	Li-ion	14.4 V DC	1.5 Ah	60 min	45 min	8860
BPL14 	Li-ion	14.4 V DC	3.0 Ah	120 min	90 min	8856

※Full charge: 0% → 100% Charge for practical use: 0% → 80%

■ Charger Specifications

Model	Power	Code No.	
BC0075G	100-240 V AC	(230V) 8900	(120V) 8896

 Caution for secure usage Be sure to read the enclosed Instruction Manual carefully and make sure that you understand them thoroughly before using this tool.

- All dimensions are nominal and subject to tolerances.
- Specifications are subject to change without prior notice.



LOBSTER LOBTEX CO.,LTD.

International Marketing Group
 TEL+81(72)981-7466 FAX+81(72)981-9420
 12-8 Shijo-Cho, Higashi-Osaka City, Osaka 579-8053 Japan
 URL : www.riveter.com www.lobtex.co.jp/

No.130-2000TO